

PRO TIPS

SPRAY GUN POSITION: Hold gun approximately 18" from surface. Keep gun square to wall. Spray horizontal strokes overlapping each stroke by 50%. Spraying too rapidly may result in a non-uniform appearance. **STEP ONE: HORIZONTAL PASS.** Remove all filters. (intake tube "Rock Catcher", manifold, gun, and prime line diffuser). Pressure Settings: Set working pressure to 800-1600 PSI (working pressure/triggered). **DO NOT EXCEED 1800 PSI.** **STEP TWO: VERTICAL PASS.** Pressure Settings: Same as horizontal pass. Hold gun approximately 18" from surface. Keep gun square to wall. Spray vertical strokes with a slow motion overlapping each stroke by 50%. Spraying too rapidly may result in a non-uniform appearance.

MATCHING SAMPLES: Positioning the spray gun 18" from surface will keep the particle size consistent throughout the installation. Particle size will increase as distance from surface increases. To achieve some colors you may need to position the gun up to 36" from the surface.

DRYING TIME: Depending on humidity and surface temperature: To touch 2-4 hours; dry hard overnight. Full film integrity for maximum abrasion and chemical resistance 7-10 days.

CLEAN-UP: Flush fluid lines and equipment with warm soapy water immediately after completion. If paint has dried, flush with lacquer thinner. Observe all applicable air/safety regulations.

COVERAGE: Up to 160 square feet per gallon, depending on pressure setting, surface porosity, surface texture and method of application.

SPRAY

MUST USE AIRLESS EQUIPMENT! Set pressure at 800-1600 psi (DO NOT EXCEED 1800 psi) and insert a 521-531 tip. Remove all filters (intake tube "Rock Catcher", manifold, gun, and prime line diffuser). Keep the spray gun positioned 18" from the surface.

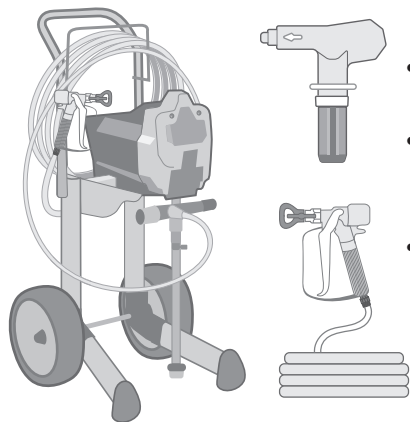

- AIRLESS SPRAYER
- SPRAY TIP: 521 – 531
521 For Smaller Particles
531 For Larger Particles
- 50' X 1/4" HOSE
Rated for 3300 psi.

REMOVE ALL FILTERS!
SET PRESSURE TO 800 - 1600 PSI

1. FIRST PASS - HORIZONTAL: Slowly!

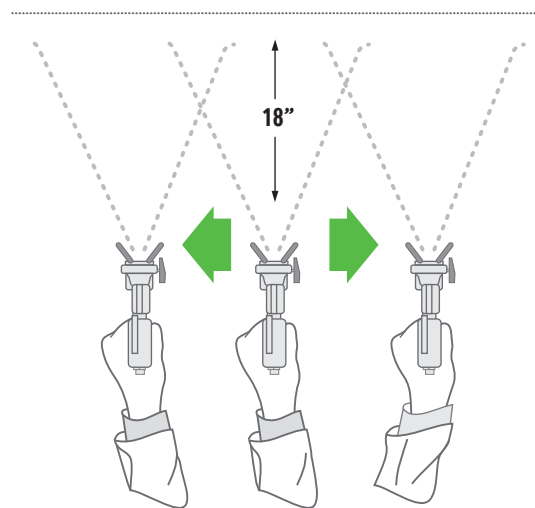

KEEP GUN SQUARE TO WALL!
1 SECOND BURSTS - 4' LONG SPRAY STROKES

2. SECOND PASS - VERTICAL: Slowly!

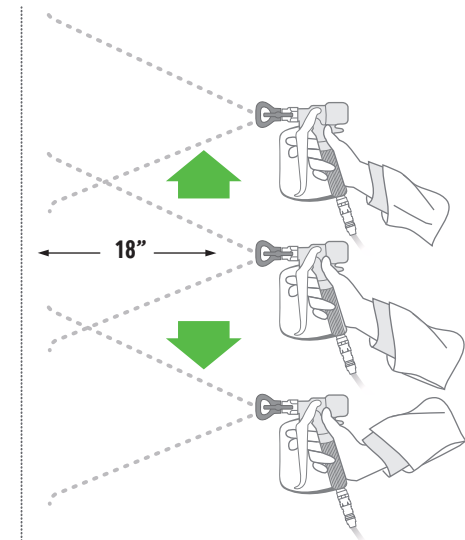

KEEP GUN LEVEL!
1 SECOND BURSTS - 4' LONG SPRAY STROKES

PRO
FOR
MAX

MOSAIC COLOR COATING

APPLICATION GUIDE

PREP SURFACE PREP: Surfaces should be clean, dry, free of dust, grease, and wax. Scuff-sand if necessary. The surface should be smooth, de-glossed, and free of defects or foreign contaminants. Surfaces should be prepared for an eggshell paint finish. When applying over new sheet-rock we recommend a level 3 finish or better.

PRIMER: DO NOT TINT. PRIMER MUST BE WHITE. If primer is applied with airless equipment, it must be back-rolled. **New drywall or plaster should be primed with ProForMax Ceramic Sphere Undercoat.** For other substrates refer to Product Data Sheet at www.ProForMax.com.

MIXING: DO NOT USE MECHANICAL AGITATOR. After opening, stir by hand with gentle rolling motion using a mud masher or paint paddle and/or box material by pouring it back and fourth from one clean container to another to achieve complete uniform consistency.

THINNING: NOT RECOMMENDED (1 - 6 oz. of water per gallon only if necessary.)

TINTING: DO NOT TINT. Mosaic Color Interior Finish is made to order and arrives tinted to the specified color.

CONTINUED

DRYWALL FINISH LEVEL: Before applying ProForMax Mosaic Color Coating, drywall should be prepared to a LEVEL 3 FINISH OR BETTER.

IMPORTANT! PRIMER MUST BE WHITE! DO NOT TINT PRIMER BEFORE APPLICATION! Using primers other than untinted White ProForMax Ceramic Sphere Undercoat will alter the performance and application of ProForMax Mosaic Color Coating and void the manufacturer warranty.

SET UP AIRLESS SPRAY APPLICATION ONLY. Use an Airless spray unit that provides 0.54 gpm or greater. We recommend the Graco Ultra Series for optimum results, starting with the basic model, Ultra 495. Utilize an LTX Series 521 or 523 spray tip, electronic pressure control with a digital display, and 50' x 1/4" hose that is rated for 3300 psi.

QUALITY ASSURANCE: Application temperature: 50°-85° with ~50% humidity or lower. Slight variations in color are considered normal and may occur due to differences in application technique or equipment. We recommend applying a mock-up area to be approved by the specifier before beginning general application.

MIXING



SLOW - BY HAND

THINNING

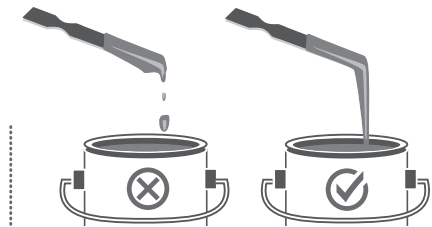

ONLY IF NEEDED
6oz. water per gal. MAX!

PRESSURE



800-1600 PSI
1800 PSI MAX

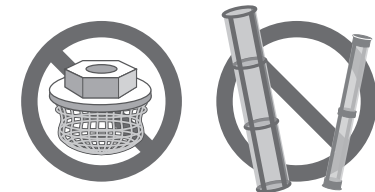

REMOVE ALL FILTERS!